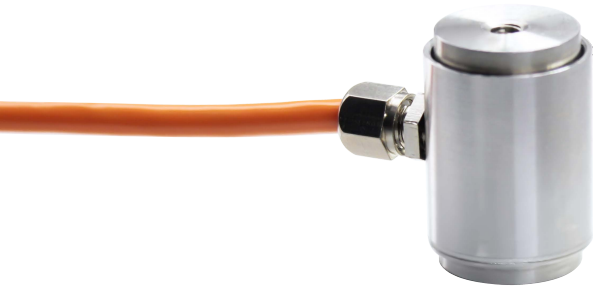

DYZ-102 柱式传感器
Column sensor

产品综述 Product Reviews

特性:

结构紧凑, 综合精度高, 长期稳定性好, 动态响应频率高, 优质不锈钢材料。

应用领域:

汽车压装、自动化组装、3C产品测试、新能源产品组装、医疗检测、机器人领域, 模具组装及其他工业测试、自动化设备领域和测试领域。

Characteristic:

It has the advantages of bi-directional tension and compression, compact structure, high comprehensive precision, good long-term stability and nickel plating on the surface of high-quality alloy steel.

Application fields:

Automobile press Ptting, automatic assembly, 3C product testing, new energy product assembly, medical testing, robotics, mold assembly and other industrial testing, automation equipment and testing pelds.

外形尺寸 External Dimension

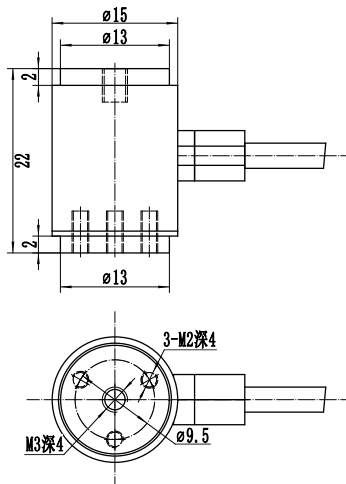

量程(kg) 10 15 20 30 50

传感器接线示意图 Sensor wiring diagram

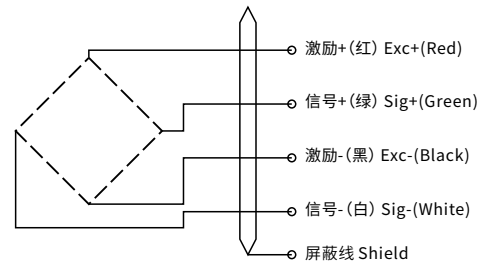

传感器受力图 Force diagram of sensor

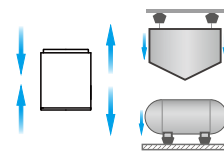

参数表 Parameters Table

量程 Capacity	0-50kg	材质 Material	不锈钢
输出灵敏度 Rated Output	2.0±10% mV/V	阻抗 Impedance	350 Ω
零点输出 Zero Balance	±2%F.S.	绝缘电阻 Insulation	≥5000M $\Omega/100VDC$
非线性 Non-Linearity	0.2%F.S.	使用电压 Operating Temp Range	5-10V
滞后 Hysteresis	0.1%F.S.	工作温度范围 Operating Temp Range	-20-80°C
重复性 Repeatability	0.1%F.S.	安全过载 Safe Overload	120%
蠕变(30分钟) Creep(30min)	0.1%F.S.	极限过载 Maximum Overload	150%
温度灵敏度漂移 Temp Effect on Output	0.1%F.S./10°C	电缆线规格 Cable Specifications	$\phi 2 \times 2m$
零点温度漂移 Temp Effect on Zero	0.1%F.S./10°C	线缆极限拉力 Cable ultimate pull	10kg
响应频率 Response frequency	10kHz	TEDS可选	